

## HOLEMAKER PRO 75

### #3 MORSE TAPER VARIABLE SPEED MACHINE



The Holemaker PRO 75 is a versatile, multi-purpose machine, equipped with a #3 Morse Taper Spindle. The 2 speed gearbox with electronic variable speed, Electronic Speed Stabilization System (ESSS), and motor soft start feature makes this machine ideal for tapping up to M24. With a large cutting capacity of 75mm diameter and 110mm depth using Holemaker Cutters, this machine will suffice for most holemaking requirements. Other standard features include gravity feed coolant system & left or right hand feed handle operation. The unique semi-automatic gib adjustment system enables simple, fast and always correct fine tuning without any expert knowledge or experience.

Supplied complete with arbor for use with Holemaker Cutters up to 75mm depth of cut.

Optional arbor to take Holemaker Cutters up to 110mm depth of cut is available.



Part No.	HMPRO75
Capacity ( Diameter )	75mm
Capacity ( Depth )	110mm
Capacity ( Twist Drill )	#3 Morse Taper 32mm
Motor Power	1650Watt
Input Power	1800Watt Single Phase 240V
Gearbox	2 Speed Gearbox with electronic variable speed and motor soft start feature 80-160; 210-420rpm
Weight	27.0kg
Magnetic Dead Lift	19500N-m on 25mm Steel Plate
Stroke	225mm
Height ( min / max )	525mm / 739mm
Through Spindle Coolant System	
Smart Magnet Technology to ensure sufficient Magnetic Adhesion	
Supplied In Metal Carry Case with Cutter Guard & Safety Strap	

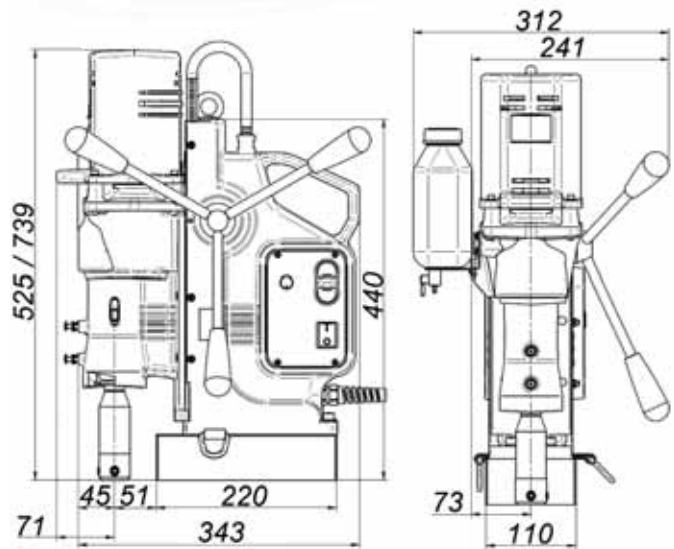

### Optional Accessories & Consumables



#### Holemaker Cutters

Over 700 different types and sizes, stocked. Our diverse range of styles and wide range of sizes means that even the most demanding jobs can be completed successfully.

- Ability to cut difficult materials such as Bissalloy, Wear Plate, Stainless Steel and Exotic Alloys
- Large diameters and depths
- General engineering
- Railway line and more!



#### #3 Morse Taper Drill Bits

Up to 32mm diameter



#### Twist Drill Chuck

Complete setup to adapt your Holemaker Machine to use twist drill bits.

# HOLEMAKER PRO 75 SR

## #3 MORSE TAPER VARIABLE SPEED MACHINE



The Holemaker Pro 75SR is as per the standard Holemaker Pro 75, but with the two additions of a swivel base system and reversible gearbox. The swivel base system makes it easier to move the machine into the correct position for drilling.

Once the drill has been fixed to the workpiece with the magnet, it can then be moved back and forward 15mm, or swiveled left and right 30°, and is then fastened into position with one socket head bolt.

The combination of both the reversible variable speed gearbox, and the swivel base system, makes this a very versatile machine that is ideal for tapping.

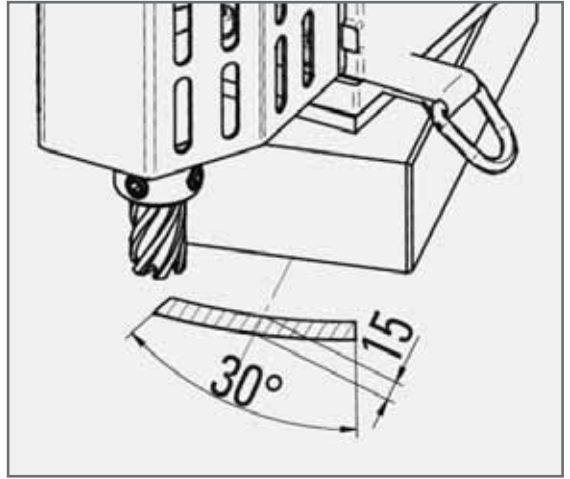

Part No.	Description
HMPRO75SR	Holemaker Pro 75 - With Swivel Base & Reverse

## TAPPING

### WITH THE HOLEMAKER PRO 75

The Holemaker Pro 75 makes difficult tapping jobs run smooth and easy. With the optional tapping head fitted, the Pro 75 will tap a maximum M20

#### Features

- Protection against tap breakage ensured by an ultra sensitive and smooth multi-position operating ball-clutch.
- Forward and reverse ball drive design transmits rotational power to the tap and disengages smoothly and silently.
- Axial float ensures smooth tapping and better thread profile.
- Cushioned drive incorporating compression and extension, eliminates the possibility of cross threadings during the tapping process, and ensures clean and accurate threads.
- A planetary gear reversing mechanism transmits smooth positive reverse to the tap retraction and it retracts 75% faster than it enters.
- Accurate depth control by means of its accurate neutral mechanism.

#### Specifications

- 20mm maximum tapping capacity
- 130mm stroke with tapping head fitted
- 168mm maximum length of tap fixed to the workpiece with the magnet, it can then be moved back and forward 15mm, or swiveled left and right 30°, and is then fastened into position with one socket head bolt.

The combination of both the reversible variable speed gearbox, and the swivel base system, makes this a very versatile machine that is ideal for tapping.



Part No.	Description
SPTH103	8-20mm Tapping Head with #3 MT