

HOLEMAKER PRO 50

#2 MORSE TAPER, DURABLE
MULTI-PURPOSE MACHINE



The ability to use Holemaker cutters, No. 2 Morse Taper shank drills & reamers, as well as a drill chuck makes this a very multi-purpose machine. Satisfying most requirements with a capacity of 52mm diameter & 75mm* depth of cut when using Holemaker cutters, and 23mm diameter using taper shank drills or reamers. An industrial 2 speed gearbox and 1260w motor provide a strong hardworking machine. Other standard features include cast iron construction, gravity feed coolant system & left or right hand feed handle operation. The unique semi-automatic gib adjustment system enables simple, fast and always correct fine tuning without any expert knowledge or experience.

Suitable for steel fabrication, engineering workshops & maintenance facilities where a heavy duty versatile machine is highly beneficial.

* Supplied complete with arbor for use with Holemaker cutters up to 52mm depth of cut. Optional arbor to take Holemaker cutters up to 75mm depth of cut is available.

Part No.	HMPRO50 (With Grub Screw Arbor)
Part No.	HMPRO50QG (With Quick Grip Arbor)
Part No.	HMPRO50D (With 75mm Depth Capacity)
Capacity (Diameter)	52mm
Capacity (Depth)	75mm
Capacity (Twist Drill)	#2 Morse Taper 23mm
Motor Power	1260 watt
Input Power	1340 watt Single Phase 240V
Speed	2 speed 200 / 400rpm
Weight	16.5kg
Magnetic Dead Lift	12000Nm On 25mm Steel Plate
Stroke	153mm
Height (min / max)	426mm / 579mm
Through Spindle Coolant System	
Smart Magnet Technology To Ensure Sufficient Magnetic Adhesion	
Supplied In Metal Carry Case With Cutter Guard & Safety Strap	

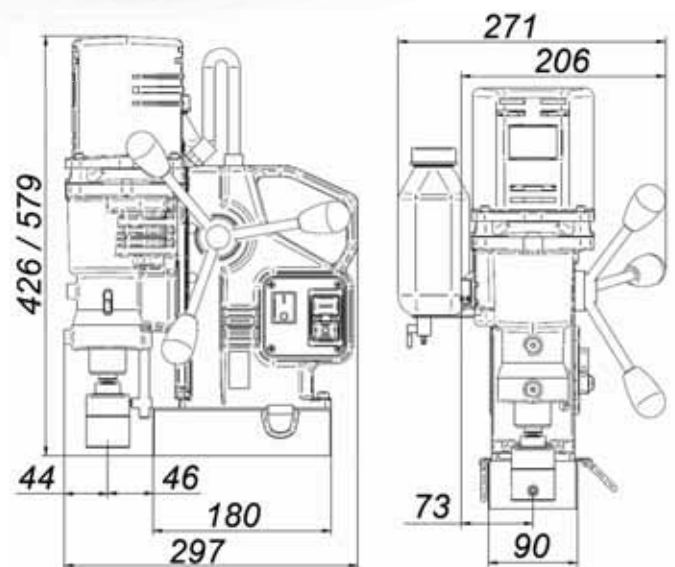

Optional Accessories & Consumables



Holemaker Cutters

Over 700 different types and sizes, stocked. Our diverse range of styles and wide range of sizes means that even the most demanding jobs can be completed successfully.

- Ability to cut difficult materials such as Bialloy, Wear Plate, Stainless Steel and Exotic Alloys
- Large diameters and depths
- General engineering
- Railway line and more!



#2 Morse Taper Drill Bits

Up to 23mm diameter



Twist Drill Chuck

Complete setup to adapt your Holemaker Machine to use twist drill bits.